CHAPTER 8

Circuit Switching and Telephone Network

Review Questions

1. Circuit switching, packet switching, and message switching.
2. Space-division and time-division
3. A crosspoint is a microswitch at the junction of an input and an output line in a crossbar switch.
4. The major limitation of a crossbar switch is the number of crosspoints required. In multistage switch, combining crossbar switches in several stages can reduce the number of crosspoints.
5. In a single crossbar switch, every combination of input and output has its own individual crosspoint. Therefore blocking does not occur.
6. In multistage switching blocking may occur when all of the possible intermediate switches are occupied.
7. In a space-division switch, the path from one device to another is spatially separate from other paths. The inputs and the outputs are connected using a grid of electronic microswitches. In a time-division switch, the inputs are divided in time using TDM. A control unit sends the input to the correct output device.
8. Time slot interchange and TDM bus
9. A TSI consists of RAM with several memory locations. The size of each location is equal to the size of a single time slot (TDM). There are as many locations as input devices. The RAM fills up with incoming data from the time slot in the order received. The control unit in the TSI sends out the slots to the correct output device. In a TDM bus, the input and output lines are connected to a high-speed bus through input and output gates. The control unit opens and closes the gates according to switching needed.
10. In TSI, the control unit makes decisions on the destination of the slots sent out, while the control unit in the TDM bus opens and closes the input and output gates according to the switching needed.
11. Space division is instantaneous, which means there are no delays when processing a connection.

12. Time-division switching does not need crosspoints.
13. The three main components of a telephone system are the local loops, the trunks, and the switching offices.
14. The local loop is a twisted-pair cable that connects the subscriber telephone to the nearest end office or local central office.
15. 4000 Hz
16. A trunk handles the communication between offices.
17. The carrier that provided services before 1996 owns the cabling system and is called the ILEC. The new carrier that can provide services is called a CLEC.
18. A POP is a switching office that is the site of interaction between inter-LATA and intra-LATA carriers.
19. The services between LATAs are handled by IXC's.
20. The signals in rotary dialing are digital; the signals in touch-tone dialing are analog.
21. In an 800 service, the callee pays for the call. In a 900 service, the caller pays for the call.
22. Analog switched service requires dialing, while analog leased service is a permanent dedicated link between two customers; no dialing is needed.
23. The DSU changes the rate of the digital data created by the subscriber's device to 56 Kbps and encodes it in the format used by the service provider.

Multiple-Choice Questions

24. b
25. d
26. b
27. c
28. b
29. a
30. d
31. d
32. b
33. a
34. d
35. a
36. b
37. c
38. c
39. d
40. b

Exercises

41. 1,000,000 crosspoints
42. 168 crosspoints
43. $20 \times 20 = 400$ crosspoints
44. Efficiency is improved by 58%.
45. Three users connected to each first stage switch can access the system at the same time (if their final destination is not the same). Twelve users can access the whole system at the same time. Three users per first stage switch and four first stage switches are used; $3 \times 4 = 12$
46. Yes, more second stage switches allow more output lines at the first-stage switches, which requires more crosspoints. The more crosspoints, the less blocking.
47. The number of simultaneous users are 12, 18, 24, and 3. Therefore, the third switch (c) has a better performance.
48. $2(N \times L) + K^2 \times L$
49.
 - Output line 1: C
 - Output line 2: D
 - Output line 3: A
 - Output line 4: B
50. Figure 8.1 shows one solution.

Figure 8.1 Exercise 50

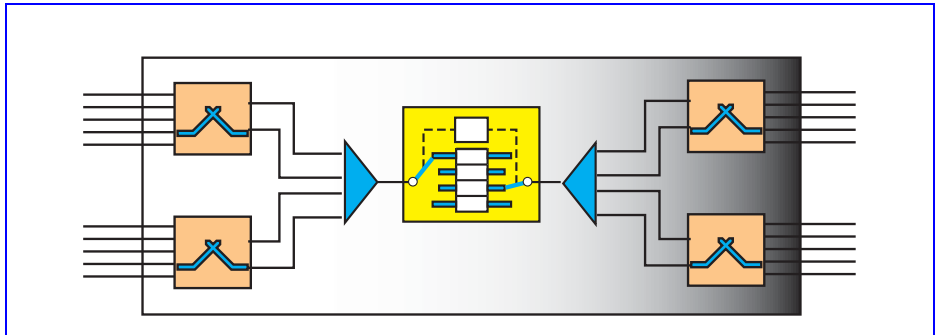

51. Figure 8.2 shows one solution.
52. Figure 8.3 shows one solution.

Figure 8.2 Exercise 51

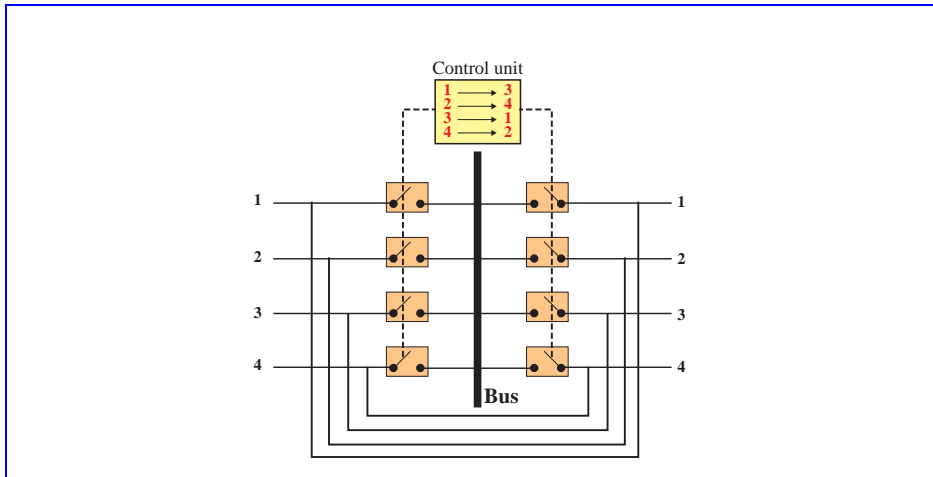

Figure 8.3 Exercise 52

