

What is Future Internet?

cshong@khu.ac.kr, Choong Seon Hong, KHU

Outline

2

- Why Future Internet?
- What is Future Internet?
- Status of Current Internet
 - ▣ History of Internet Growth
 - ▣ Merits and Demerits of Future Internet
- Summary of research effort of Future Internet
 - ▣ FIND, GENI, FIRE, JGN2, AsiaFi, etc
- Challenges & Requirements of Future Internet
- Architecture of Future Internet
- Concluding Remarks

Why Future Internet?

3

- A growing and changing demand
 - ▣ For increasing user control of contents/services
 - ▣ For interconnecting 'things'-TV/PC/phone/sensor...
 - ▣ For convergence: networks/devices/services
(video/audio/data/voice)
 - ▣ Mobility
 - ▣ Security
- Current technologies can be, and need to be improved significantly
 - ▣ For scaling up and more flexibility
 - ▣ For better security
 - ▣ For higher performance and more functionality

What is Future Internet? (1)

4

- Need to resolve the challenges facing today's Internet by rethinking the fundamental assumptions and design decisions underlying its current architecture
- Two principal ways in which to evolve or change a system
 - ▣ **Evolutionary approach (Incremental)**
 - A system is moved from one state to another with incremental patches
 - ▣ **Revolutionary approach (Clean-slate)**
 - The system is redesigned from scratch to offer improved abstractions and/or performance, while providing similar functionality based on new core principles
- It is time to explore a clean-slate approach
 - ▣ In the past 30 years, the Internet has been very successful using an incremental approach
 - ▣ Reaching a point where people are unwilling or unable to experiment on the current architecture

What is Future Internet? (2)

5

- Future Internet?
 - ▣ **Clean Slate** design of the Internet's architecture to satisfy the growing demands
 - ▣ Management issues of Future Internet also need to be considered from the stage of design

- Research Goal for Future Internet
 - ▣ Performing research for Future Internet and designing new network architectures
 - ▣ Building an experimental facility

What is Future Internet? (3)

6

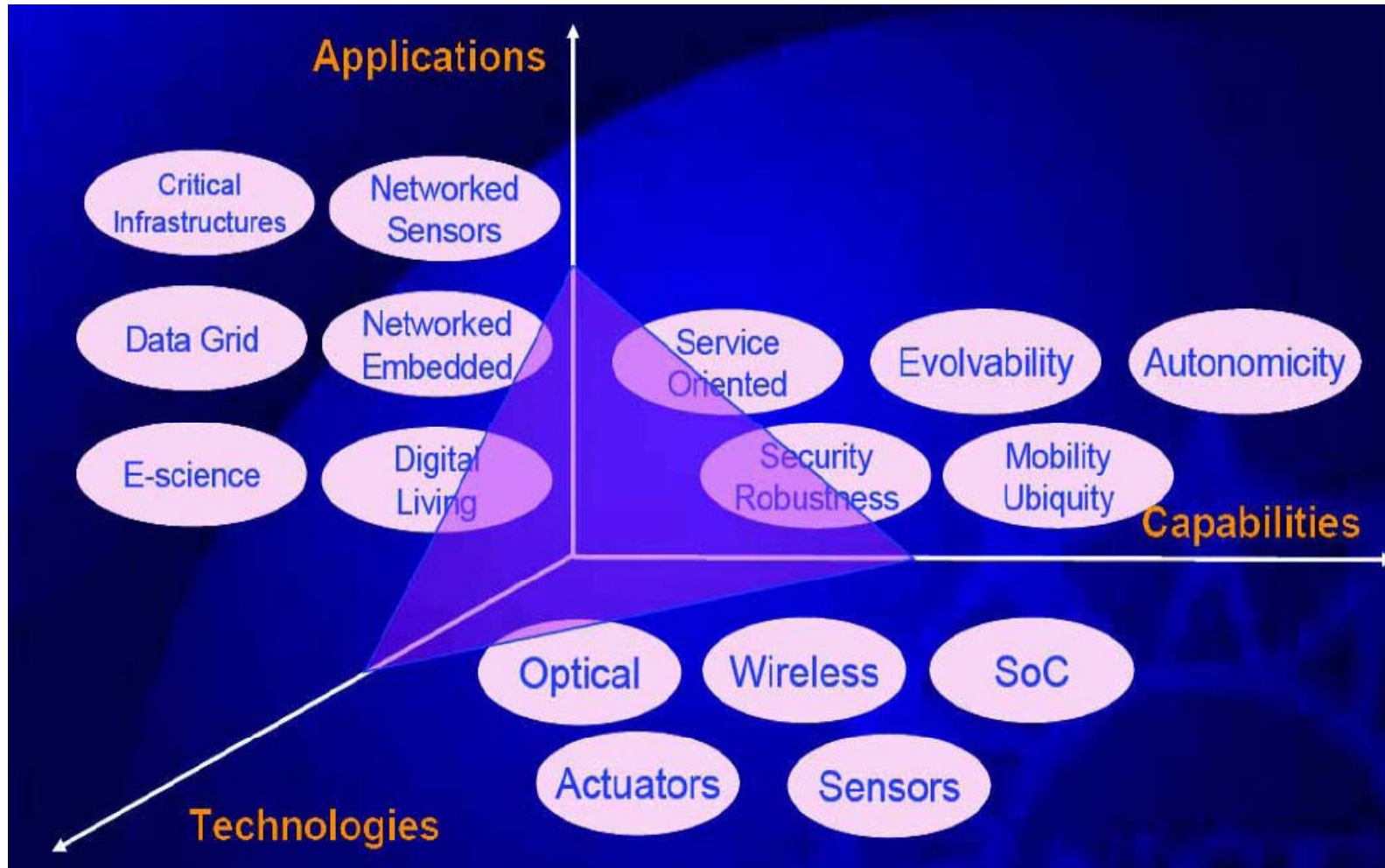

Need a 'clean-slate' approach

History of Internet Growth (1)

7

- Stage One: **Research and Academic Focus** (1980-1991)
 - ▣ Debate about which protocols will be used (TCP/IP)
 - ▣ The National Science Foundation (NSF) took a leading role in research networking
 - NSFNet1: “supercomputer net”
 - NSFNet2: a generalized Internet (thousands of Internet nodes on U.S campus)
 - ▣ The Internet Engineering Task Force (IETF) created open standards for the use of the Internet
 - Request for Comments (RFC) standards documents

History of Internet Growth (2)

8

- Stage Two: **Early Public Internet** (1992-1997)
 - Federal Networking Council (FNC) made a decision to allow ISP to interconnect with federally supported Internets
 - The National Center for Supercomputing Applications (NCSA) adopted Tim Berners-Lee's work on the World Wide Web
 - Mosaic, Netscape started us down the path to the browser environment today
 - It was watershed development that shifted the Internet from a command-line, e-mail, and file-transfer kind of user interface to the browser world of full-screen applications
 - In the fall of 1996, a group of more than thirty University Corporation for Advanced Internet Development (UCAID)
 - Subsequently become known as Internet2

History of Internet Growth (3)

9

- Stage Three: **International Public Internet** (1998-2005)
 - The Internet achieved both domestic and international critical mass of growth
 - Fueled by giant bubble in Internet stocks that peaked in 2000 and then collapsed
 - Fiber-optic bandwidth Improvements to gigabit-per-second levels, and price-performance improvements in personal computers
 - xDSL, FTTH, etc.
 - The “bubble” years laid the foundation for broadband Internet applications and integration of voice, data, and video services on one network base

History of Internet Growth (4)

10

- Stage Four: **Challenges for the Future Internet (2006-?)**
 - The Internet has become a maturing, worldwide, universal network
 - Currently debated policy issues: net neutrality
 - Two of the few surviving U.S. telcos intended to levy special surcharges on broadband Internet traffic based on the application and on the company
 - Millions of Internet users
 - Growth in functionality and value of the net could never have happened if there had been discrimination in managing packet flow
 - If the telco's well funded campaign succeeds
 - Then Progress toward universal and affordable broadband access will be further delayed

Merits & Demerits of Current Internet

11

□ Merits

- The original Internet design goal of robustness
 - Network architecture must not mandate recovery from multiple failures, but provide the service for those users who require it
- Openness: low barrier to entry, freedom of expression, and ubiquitous access

□ Demerits

- “Nothing wrong – just not enough right”
- Pervasive and diversified nature of network applications require many functionalities
 - Current network architecture doesn’t support
- E.g., TCP variants for high bandwidth delay product networks, earlier work on TCP over wireless networks, and current effort towards cross-layer optimization

Research Institute for Future Internet

12

- US NSF
 - ▣ Future Internet Design (**FIND**)
 - ▣ Global Environment for Networking Innovations (**GENI**)
- European Commission
 - ▣ Future Internet Research and Experimentation (**FIRE**)
 - ▣ EIFFEL's Future Internet Initiative
 - ▣ EuroNGI & EuroFGI
- AsiaFI by CJK
- JAPAN
 - ▣ NICT's NeW Generation Network (**NWGN**)
 - ▣ Japan Gigabit Network II (**JGN2**)
- KOREA
 - ▣ Future Internet Forum (**FIF**)

US NSF - NeTS

13

□ National Science Foundation (NSF)

- ▣ An independent federal agency created by Congress in 1950
- ▣ Supports for all fields of fundamental science and engineering
- ▣ With an annual budget of about \$5.92 billion

□ Networking Technology and Systems (NeTS)

- ▣ A program in NSF
- ▣ Covers all properties of information networks including network architecture, protocols, algorithms, and proof of concept implementation of hardware and software
- ▣ Funding: approximately \$40 million per year
- ▣ Four areas of networking research
 - Future Internet Design (FIND)
 - Wireless Networks (WN)
 - Networks of Sensor Systems (NOSS)
 - Networking Broadly Defined (NBD)

US NSF – CISE

14

- Computer Information Science and Engineering (CISE)
- The Directorate for CISE has three goals:
 - ▣ To enable the U.S. to uphold a position of world leadership in computing, communications, and information science & engineering
 - ▣ To promote understanding of the principles and uses of advanced computing, communications and information systems in service to society
 - ▣ To contribute to universal, transparent and affordable participation in an information-based society
- CISE is organized in three divisions:
 - ▣ the Division of Computing & Communication Foundations (CCF)
 - ▣ the Division of Computer and Network Systems (CNS)
 - ▣ the Division of Information and Intelligent Systems (IIS)
- Supports GENI project

FIND (1)

15

- What is FIND?
 - ▣ Major new long-term initiative of NSF NeTS research program
 - ▣ Created in 2006
 - ▣ Funded project seeking to design a next-generation Internet called the 'Future Internet'
- Research goal
 - ▣ About end to end network architecture & design as well as implications of emerging technologies on Future Internet
 - ▣ Invites the research community to consider
 - What the requirements should be for a global network of 15 years from now
 - How we could build such a network if we are not constrained by the current Internet - if we could design it from scratch

FIND (2) - Status

16

- Three phases
 - ▣ Each phase will last about three years
 - ▣ **Phase 1** (current phase: 2006~2008): focuses on components or parts of an architecture such as new schemes for security, naming, or routing
 - 2006: Funded 26 projects
 - July, 2007: Proposals are evaluated
 - Three FIND research meetings/year
 - ▣ **Phase 2** (2009~2011): proposes overarching network architectures using research and knowledge gained from the 1st phase
 - ▣ **Phase 3** (2012~2014): demonstrates ideas on experimental infrastructure (GENI)

GENI (1)

17

- What is **GENI**?
 - ▣ A planning effort initiated by the NSF CISE Directorate
 - ▣ Experimental facility to validate research (infrastructure to demonstrate research)
 - ▣ A nationwide programmable facility for research into Future Internet technologies
 - ▣ Launched in August 2005
- Consists of two components
 - ▣ **GENI research program(s)**: will continue CISE's long-term support for basic research and experimentation in networking and related topics
 - ▣ **GENI research facility**: will be a state-of-the-art, global experimental facility that will foster exploration and evaluation of new networking architectures (at scale) under realistic conditions

GENI (2) – Status

18

YEAR	Activity
1970s~today	Funding of networking research and infrastructure
2002	Network Research Testbeds Program Experimental Infrastructure Networks Program
2003	Network simulation, emulation, and experimental facilities funded (~\$20M)
2004	Consolidation of networking research programs into a larger new program NeTS with emphasis on next generation networks that go beyond Internet (~\$40M/yr)
2005	CISE GENI team formed Five GENI facility planning grants
2006	Facility Conceptual Design Creation of the Computing Community Consortium (CCC)
2007	The formative stages 'GENI Science Plan' revision GENI Facility 'Conceptual Design' almost completed
Late 2008	Beginning of construction

Research in EU (1)

19

- The Seventh Framework Programme for research & technology development (FP7)
 - The main financial tools through which the European Union supports research and development activities covering almost all scientific disciplines
 - FPs have been implemented since 1984 and generally cover a period of five years with the last year of one FP and the first year of the following FP overlapping
 - FP7: 2007 ~ 2013 (7 years)
- Information and Communication Technologies (ICT)
 - One of the major research themes in FP7
 - Critical to improve the competitiveness of European industry and to meet the demands of its society and economy

Research in EU (2)

20

- FP6/IST (Information Society Technologies)/FET (Future Emerging Technologies)/FIRE → FP7/ICT/FIRE
- **EIFFEL** (Evolved Internet Future for European Leadership)
 - Launched by the EU Commission (J. Da Silva, **July 2006**) as a support action (SA) for FP7
 - Group of **technical experts** acting as an individual
 - Forms Future Internet Initiative (<http://www.future-internet.eu>)
 - Released a white paper in December 2006
 - Structure: 4 working groups
 - Evolution scenarios, technological and socio-economic drivers
 - Technical challenges
 - Policy challenges
 - Planning and coordination group

FIRE (1)

21

□ What is FIRE?

- An activity or initiative aims to scope and consolidate the European work in networking testbeds

□ Goal

- Aims at **providing a research environment for investigating and experimentally validating** highly innovative and revolutionary ideas on future Internet

□ FIRE Status

- *January 2007*: Preliminary meeting between Panlab and OneLab
- *14-15 Feb 2007*: First FIRE expert group meeting, Brussels
 - Expert groups to define a long-term vision, and to build a multidisciplinary constituency
- *6-7 March 2007*: FIRE workshop, Zurich
 - *June*: Publication of the final report of the FIRE expert groups
- **Sept. 10, 2008, FIRE LAUNCH - Event and Workshop**

FIRE (2)

22

Objective ICT-2-1.6 : "New Paradigms and Experimental Facilities"

Proposals selected under ICT Call 2 to start in Spring/Summer 2008

14 projects, 40,38M€

Co-ordination and Support Actions

FIREWORKS

PARADISO

Main focus on experimentally driven advanced research for the Future Internet

OPNEX

ECODE

N4C

SmartNet

Perimeter

NANO
DATACENTERS

ResumeNet

SelfNet



Main focus on interconnecting test-beds towards building an experimental facility for the Future Internet

VITAL++

WISEBED

PII

OneLab2

Testbed

Testbed



Integrated project



Focused project
(STREP)



Coordination & support actions



FIRE (3)

23

- Two related dimensions
 - **Promoting** experimentally-driven *long-term research* on new paradigms and networking concepts & architectures for the future Internet
 - **Building** a sustainable, dynamic, large scale *experimentation facility* by gradually *federating* existing and new testbeds for emerging or future internet technologies
- The expected impact is :
 - Strengthened European position in the development of the Future Internet
 - Global consensus towards standards and strengthened international co-operation through interconnected test beds and interconnection capabilities offered to third countries
 - Higher confidence in the secure use of the Internet through test beds enabling trusted access to e-Services

JAPAN – NWGN (1)

24

- NeXt Generation Network (NXGN)
 - ▣ Improvement of IP networking to provide Triple-/Quadruple-play services
- NeW Generation Network (NWGN)
 - ▣ Network architectures and main protocols are different from IP networks

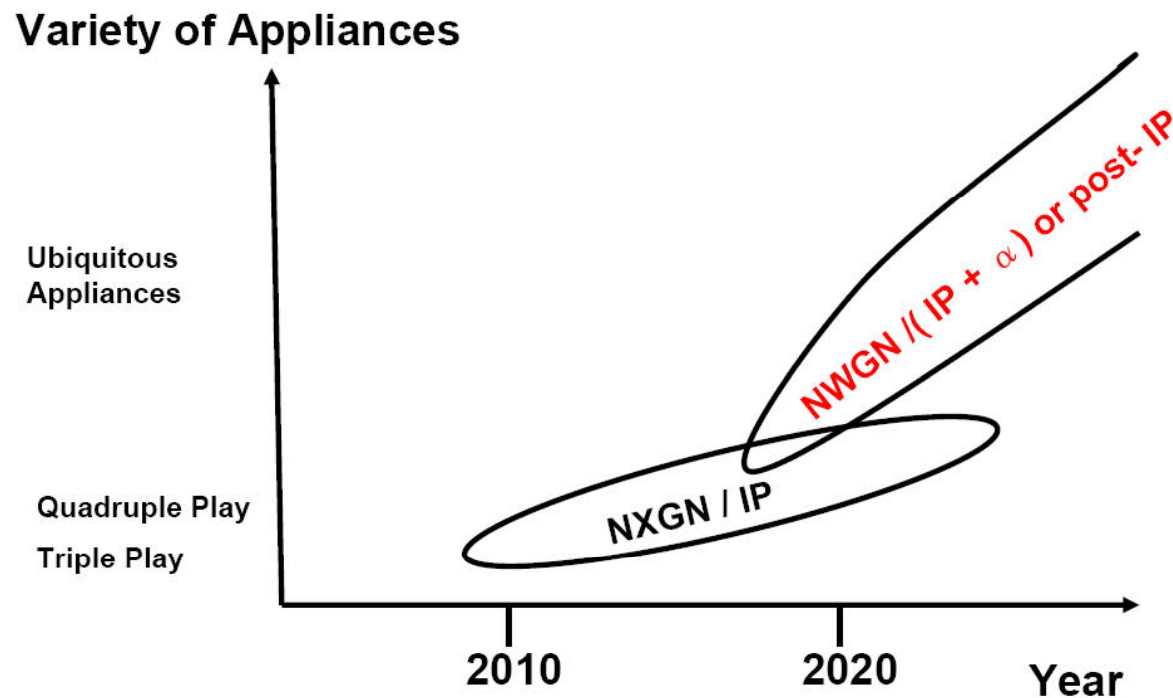

JAPAN – NWGN (2)

25

- NXGN is now being deployed, standardized, and invested toward the service start in 2007
- NWGN is in the research phase
 - ▣ Various projects funded by NICT (National Institute of Information & Communications Technology) from underlay networking to applications
 - ▣ MIC is making a new report on a policy for future network research projects which Japanese Government should support
 - ▣ All Japan Forum for future network research will be established soon for global collaboration

JAPAN - JGN2

26

- NICT has launched the JGN2 project with an open testbed network
 - Aims to realize the research and development for Information Communication Technology
 - Since April 2004 following the project of JGN (Japan Gigabit Network) from April 1999 to March 2004
 - In collaboration with the industry, the academia, the government and regional organizations
 - Supports activities from the basic or fundamental research and development to the demonstrative experimental testing towards practicalities
 - Fosters the research of network-related technologies with diverse ranged applications for the next generation
 - Can be utilized by any user if its utilization purpose is research and development

AsiaFI

27

- Found in 2007.7 (www.asiafi.net)
 - Asia Future Internet Forum (AsiaFI) was founded to coordinate research and development on Future Internet among countries in Asia as well as with other continents. In order to coordinate the research and development, AsiaFI carries the following activities among others;
 - Education Committee (chair: CS Hong,
Co-chairs : Jun Bi, Koji Okamura)
 - WG :
 - [Architecture & Building Blocks Working Group](#)
 - [Mobile & Wireless Working Group](#)
 - BoF : Testbed

KOREA - FIF

28

- Future Internet Forum (FIF)
- 1st BOF
 - Several researchers started an informal meeting in April, 2006
 - Several monthly BOF meetings followed
- First forum meeting –September, 2006
 - First stage: to June, 2007
 - Review prior activities related to future Internet research
 - Second stage
 - Propose areas that we can contribute most
 - Problem definition
- WGs–February, 2007
 - WGs: Architecture, wireless, service & testbeds
- 3rd International Conference on Future Internet (June 2008)

FIF – Research activities

29

- Propose research projects to MIC (Ministry of Info. & Comm.):
Fall, 2006
- Granted a three year research funding
 - ▣ 2007 to 2010
 - ▣ About 1.3 M / year
 - ▣ 15 Professors
- Topics
 - ▣ Naming, routing
 - ▣ Large-capacity switching
 - ▣ Wireless networking
 - ▣ LBS & context-aware services
- Existing testbed networks
 - ▣ KOREN, KREONET
 - ▣ Plan to extend to experiment FI protocols and ideas

Research Roadmaps of Future Internet

30

- Roadmaps of Future Internet in EU, US and JAPAN

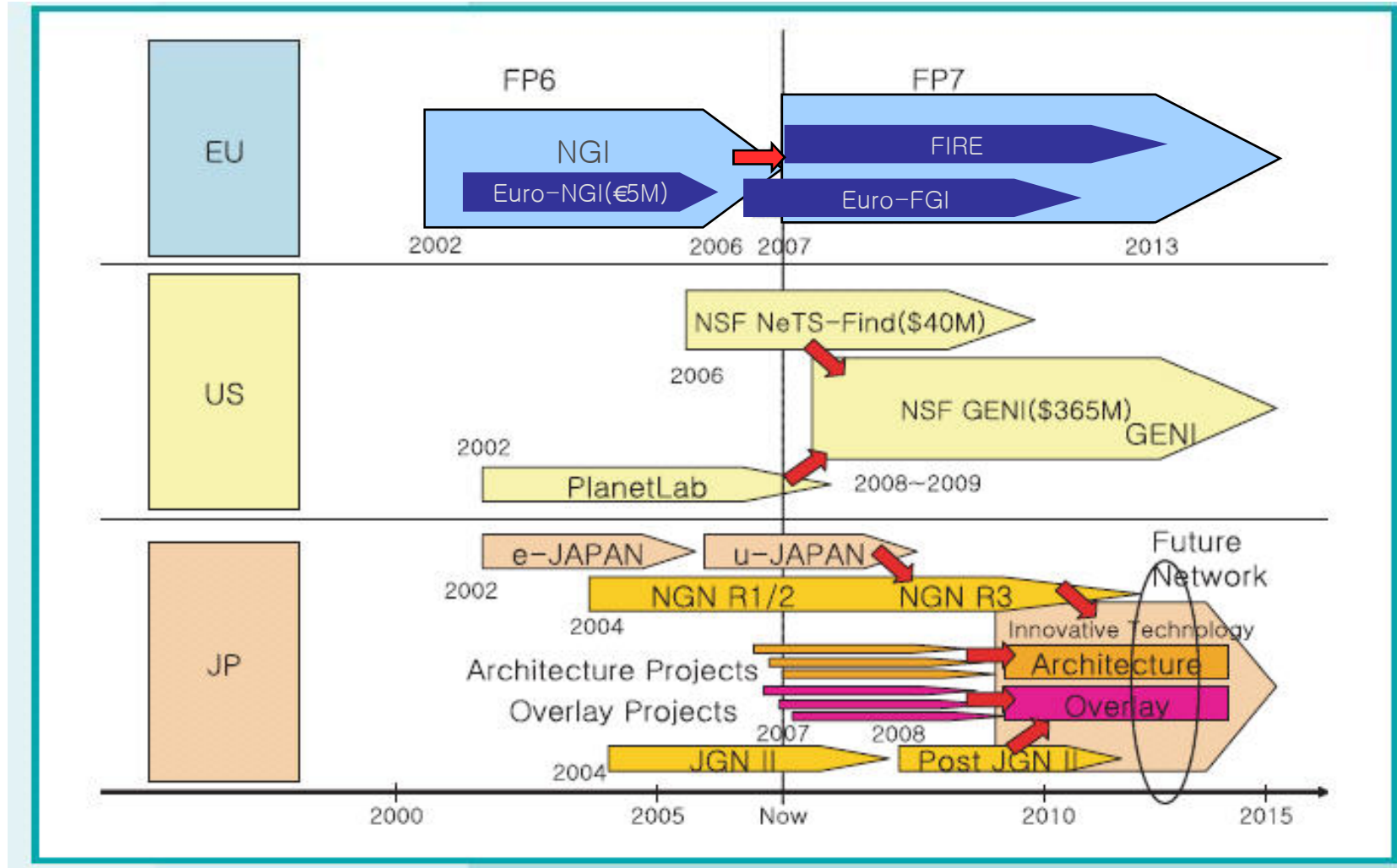

Challenges of the Internet

31

- Security
 - ▣ Worrisome to everyone (user, application developers, operators)
- Mobility
 - ▣ Little support for mobile applications and services
- Reliability and Availability
 - ▣ ISPs face the task of providing a service which meets user expectations
- Problem analysis
 - ▣ Toolset for debugging the Internet is limited
- Scalability
 - ▣ E.g., routing system
- Quality of Service
 - ▣ It is unclear how and where to integrate different levels of QoS
- Economics
 - ▣ How network and service operators continue to make a profit

Requirements of Future Internet

32

- Highly available information delivery
- Verifiably secure information delivery
- Support for mobility
- Interworking flexibility and extensibility
- Support for a scalable, unified network
- Explicit facilitation of cross-layer interactions
- Distribution of data and control

Architecture

33

□ Keywords

□ Virtualization

- Virtualize network resources and provide customer-specific services

□ Programmable

□ Service-oriented architecture (SOA)

- Define layer's functions as services and converge the services to support the network operations
- Register services, discover services in repository and acquire necessary services

□ Cross-layer design

- Divide network layers and support a cross-layer mechanism

Virtualization - GENI

34

- Virtualize network resources and provide customer-specific services

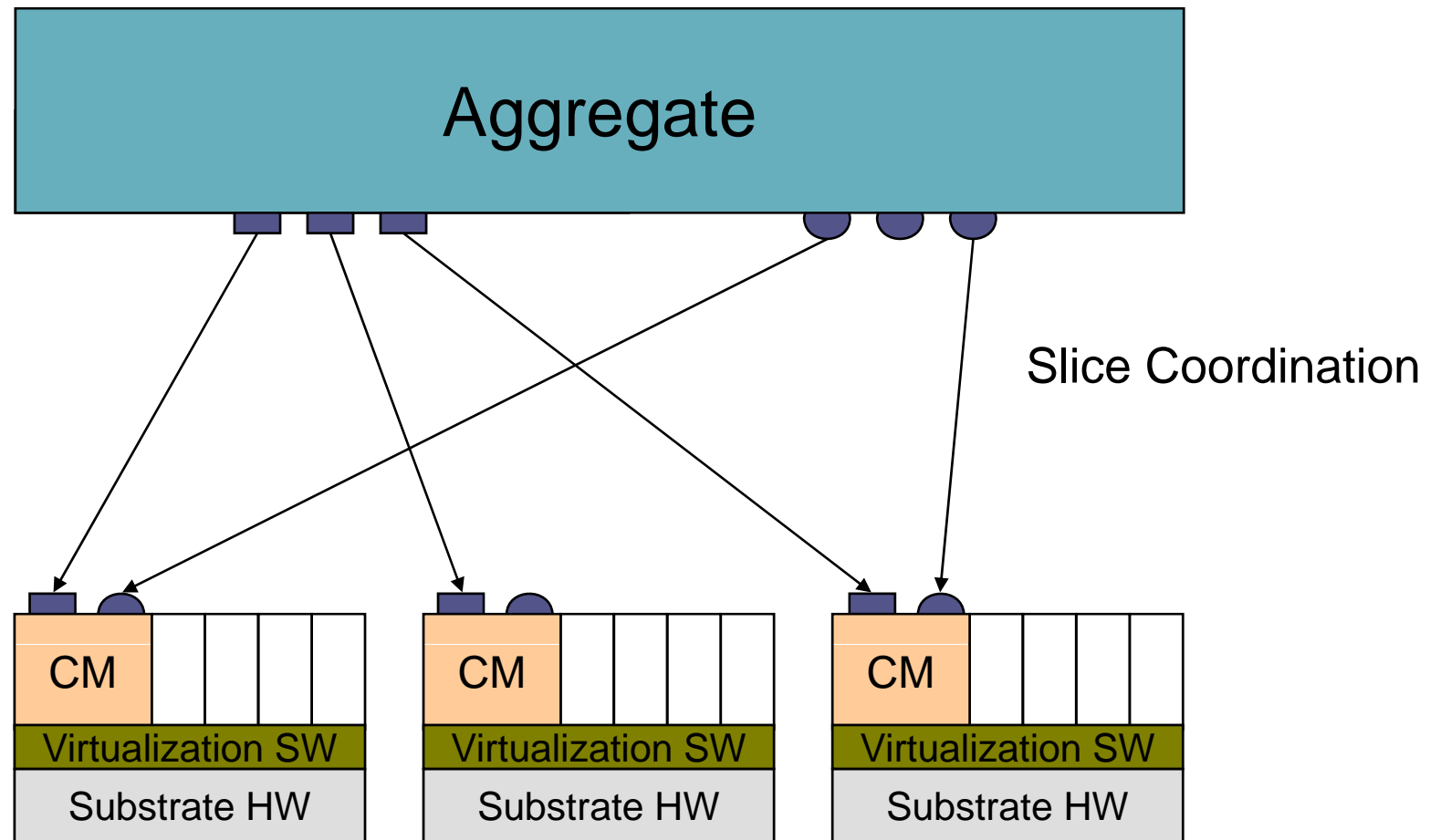

CM : Component Manager

Programmable Substrate - GENI

35

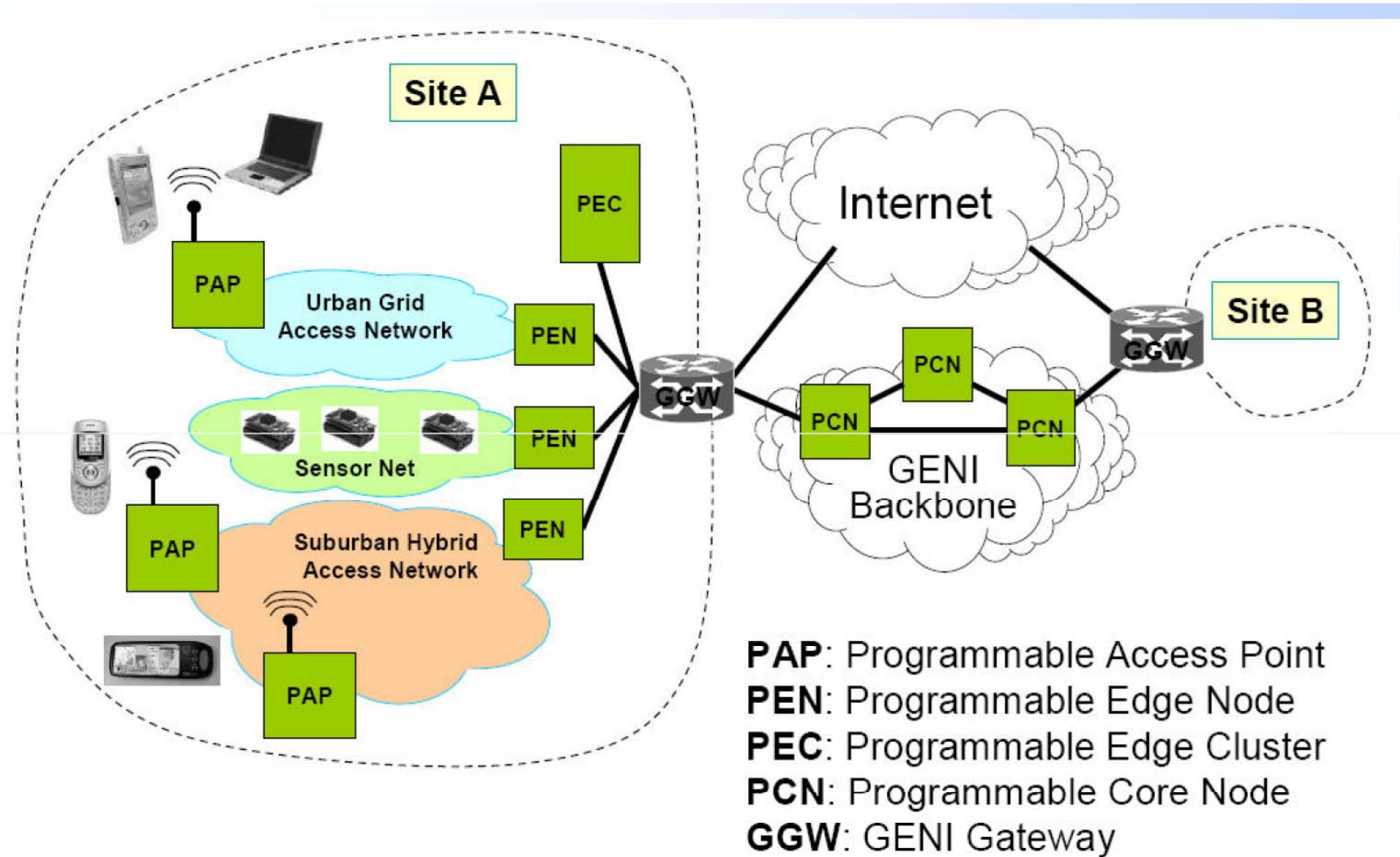

SOA (1) – FIND's SILOS

36

- Define layer's functions as services and converge the services to support the network operations

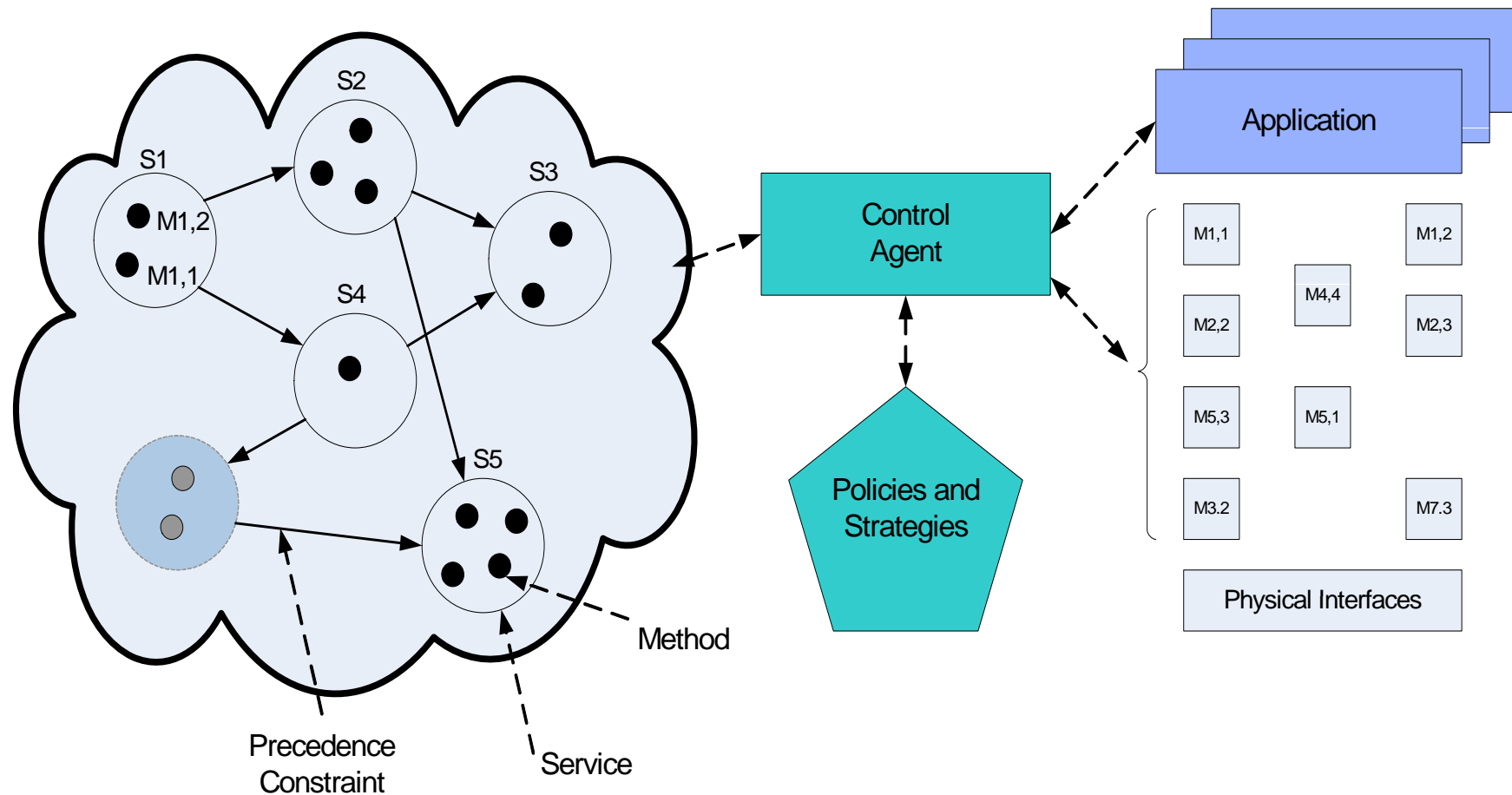

SOA (2)

37

- Register services, discover services in repository and acquire necessary services

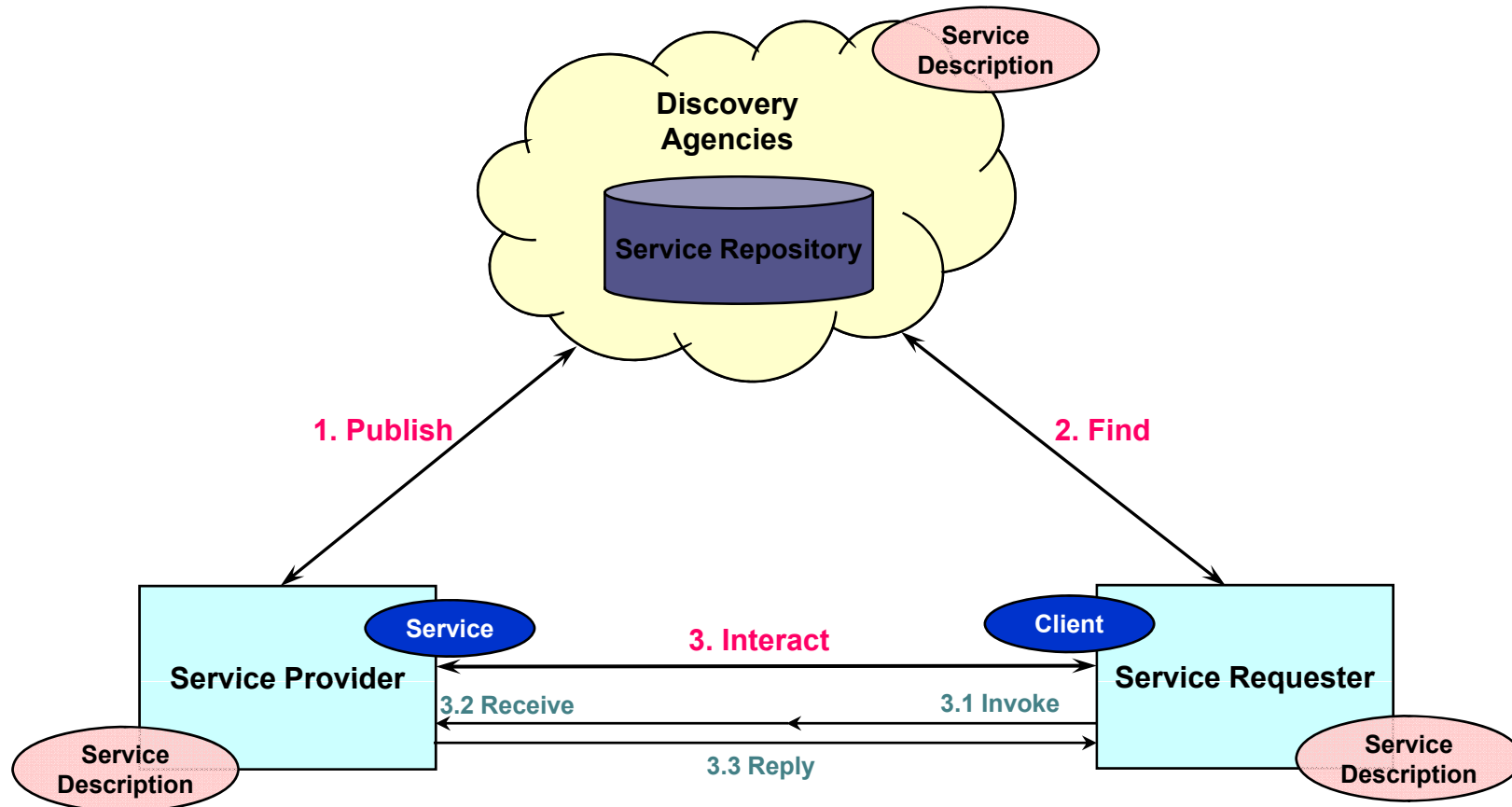

Cross-Layer Design – JGN2

38

- Divide network layers and support a cross-layer mechanism

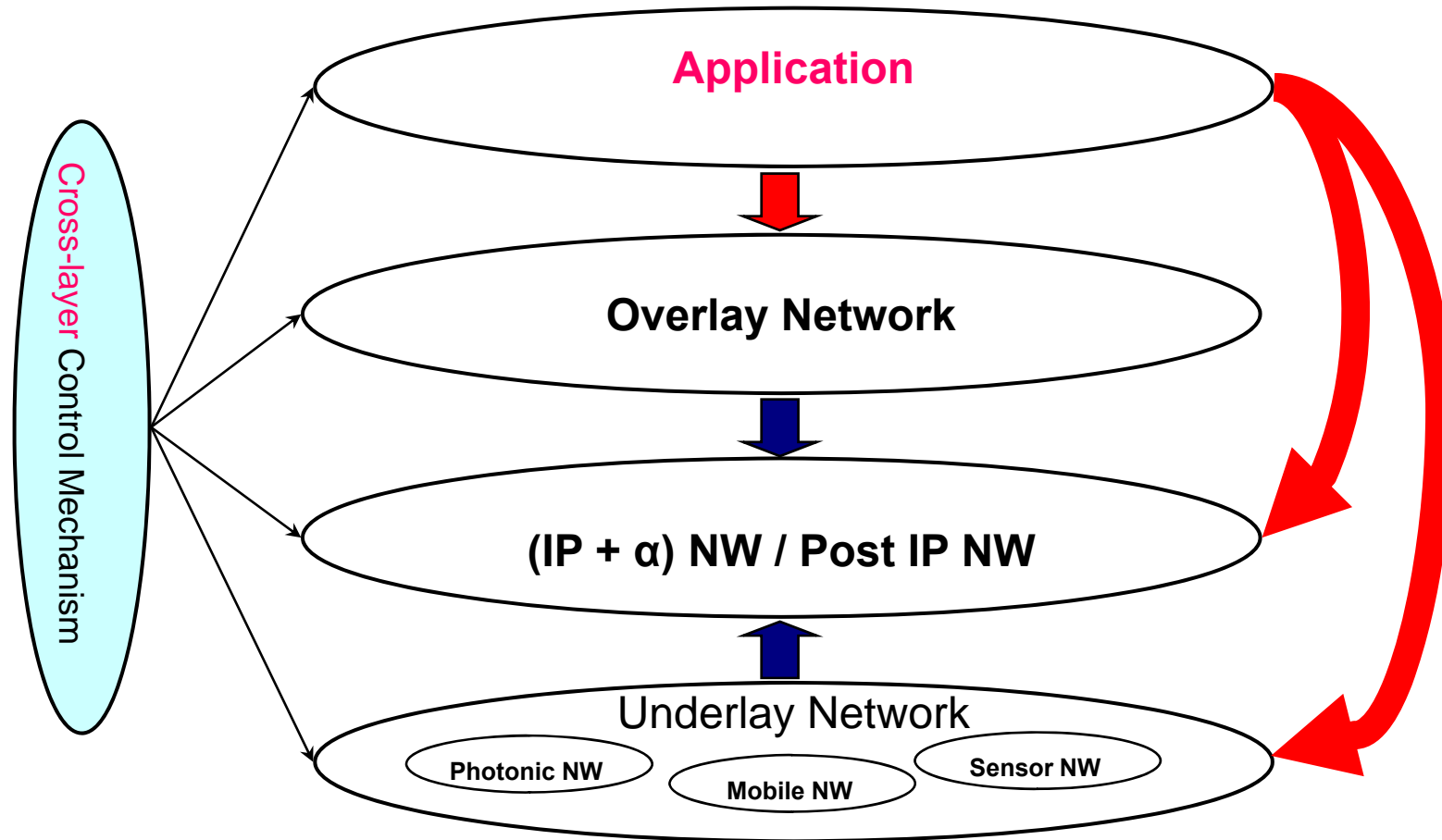

Integrated Architecture

39

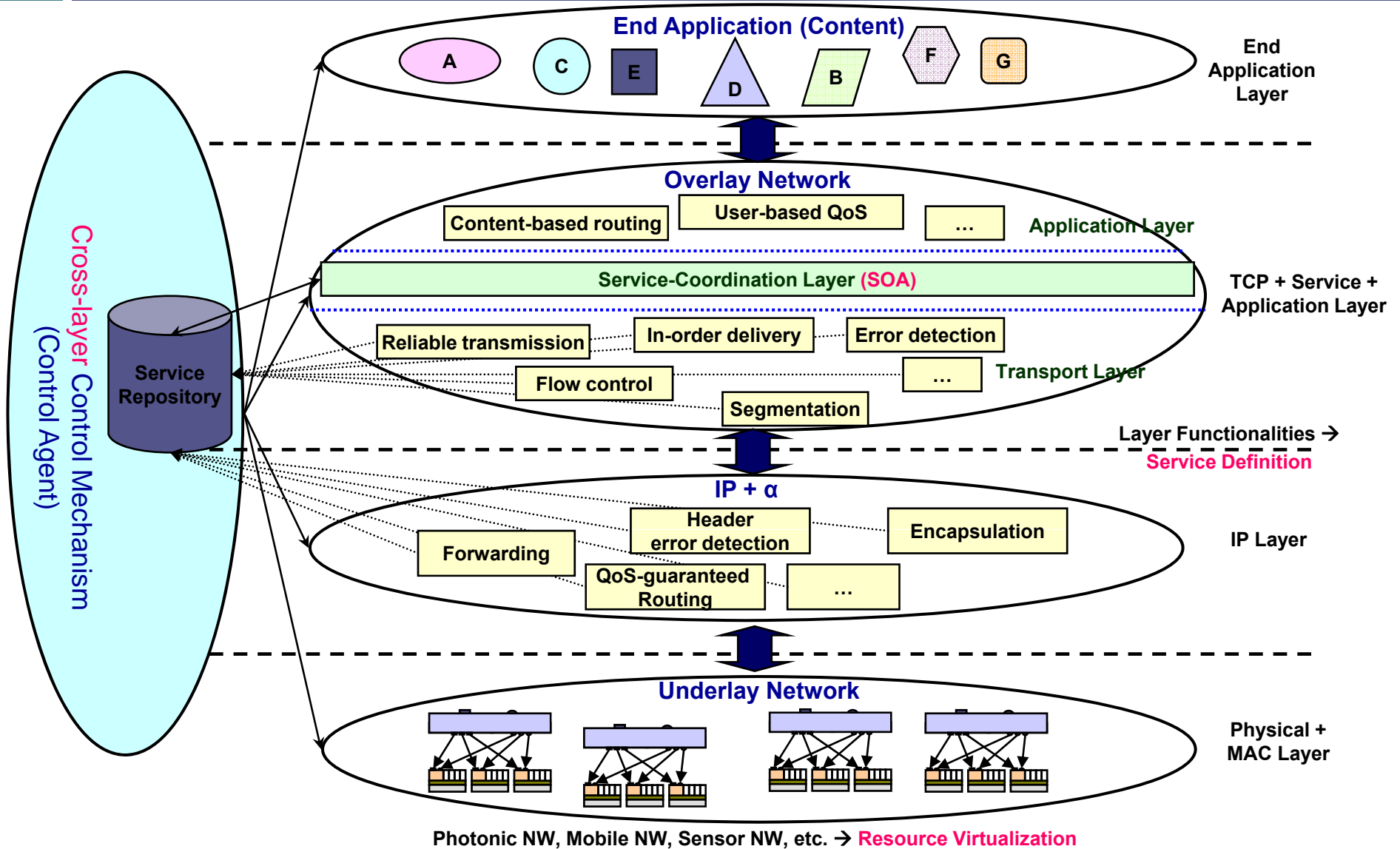

Concluding Remarks

40

- Current Internet
 - ▣ Root cause of problem: tremendous pace of increase of its use
 - ▣ Merits: openness, freedom of expression and ubiquitous access
 - ▣ Challenges: mobility, scalability, security & privacy, addressing & identity, robustness, manageability, etc.
- Future Internet
 - ▣ **Clean slate design** of Internet architecture considering **security**, scalability, mobility, robustness, identity, **manageability**, etc.
- Research Goal
 - ▣ Performing research for Future Internet and designing new network architectures
 - ▣ Building an experimental facility
- Propose an integrated architecture of Future Internet
- Investigate possible research topics towards management of Future Internet
 - ▣ In a design phase, we can imagine all possible mechanisms to solve the drawbacks of current Internet
 - ▣ How can we validate our proposed architecture and management issues?
 - ▣ What topic can we focus on?

References

41

- Course material of DPNM of POSTECH, Spring 2008
- www.asiafi.net
- www.fif.net
- www.geni.net
- www.eurongi.net
- www.jgn2.jp
- <http://cordis.europa.eu/fp7/ict/fire/>
- cfit.ucdavis.edu/internet_futures/
- <http://net.educause.edu/ir/library/pdf/ERM0640.pdf>
- http://www.panlab.net/fileadmin/documents/FIRE/FIRE_report_14_June_2007_distribution_info_day.pdf

Question and Discussion

42

