



A Recursive Network Architecture

Joe Touch
Postel Center Director
USC/ISI
Research Assoc. Prof.
USC CS and EE/Systems Depts.





Outline

- Towards future network architectures
- Background on X-Bone VNs
- RNA
 - Intro.
 - Design
 - Implementation
 - Implications
 - Related work



What makes an architecture new?

- Shaking the Hourglass (CCW 08)
 - All exchanges are 1 packet
 - Collosograms $> RTT * delay$
 - No LANs? (L2 is only pt-pt)
- What defines success?
 - Fixing what's 'broken'
 - Doing something new/different
 - The Internet / circuits as a degenerate case



Internet Architecture

Accused of ossification, but:

- Ossification = stability
- Flexibility is abundant:
 - Shim layers:
 - HIP, SHIM6, IPsec, TLS
 - Muxing layers:
 - SCTP, RDDP, BEEP
 - Connections:
 - MPLS, GRE, IKE, BEEP, SCTP
 - Virtualization:
 - L2VPN, L3VPN/X-Bone/RON/Detour, L7-DHTs



Motivation

- Desire to support new capabilities
 - Interlayer cooperation, dynamic layer selection, layering created by virtualization
- Desire to support emerging abstractions
 - Overlay layers don't map to 1-7
 - Support for recursive nodes (BARP, LISP, TRILL)
- Desire to coordinate services in diff. places
 - Security, soft-state, pacing, retransmission



Observations

- Networking is *groups of interacting parties*
 - Groups are heterogeneous
 - All members want to interact
 - Groups can be dynamic (*i.e.*, virtual)
- Need an architecture that supports:
 - Heterogeneity
 - Interaction
 - Virtualization



Heterogeneity leads to layering

- M different interacting parties need
 - M^2 translators



or

- M translators + common format
- ... *i.e.*, a layer





Interaction leads to forwarding

- N parties need

- N^2 circuits



or

- $O(N)$ links + forwarding





Virtualization leads to recursion

- N parties want to group in arbitrary, dynamic ways.
 - ... such groups are inherently virtual

- ... and virtualization is inherently recursive



What makes this an architecture?

- Abstraction for virtualization
 - Tunnel as link
 - Partitioned router as virtual router
 - Partitioned host + internal router as virtual host
- Abstractions for recursion
 - Recursive router implemented as a network of routers with vhosts at the router interfaces
 - Recursion within the protocol stack
- General template (metaprotocol + MDCM)
 - Instantiates as different layers or forwarding



Virtual Net Req'ts

- **Internet-Compliant Architecture**
 - Hosts add/delete headers
 - Routers transit (constant # headers)
- **Supports New Capabilities**
 - Concurrence (multiprocessing)
 - Revisitation (multiple roles in one net)
 - Recursion (to hide topology and/or mgt.)



VN Principles

- *TENET 1. Internet-like*
 - VIs = VRs + VHs + tunnels
 - Emulating the Internet
- *TENET 2. All-Virtual*
 - Decoupled from their base network
- *TENET 3. Recursion-as-router*
 - Some of VRs are VI networks



VN Architecture

- Components:
 - VH -> hosts include a hidden router
 - VL -> 2 layers of encaps. (strong link, weak net)
 - VR -> partitioned forwarding
- Capabilities:
 - Revisitation -> multihoming for VNs
 - Recursion -> router as network, i.e., Rbridges, LISP

>> RUNNING CODE (FreeBSD, Linux, Cisco)



Recursive Internet

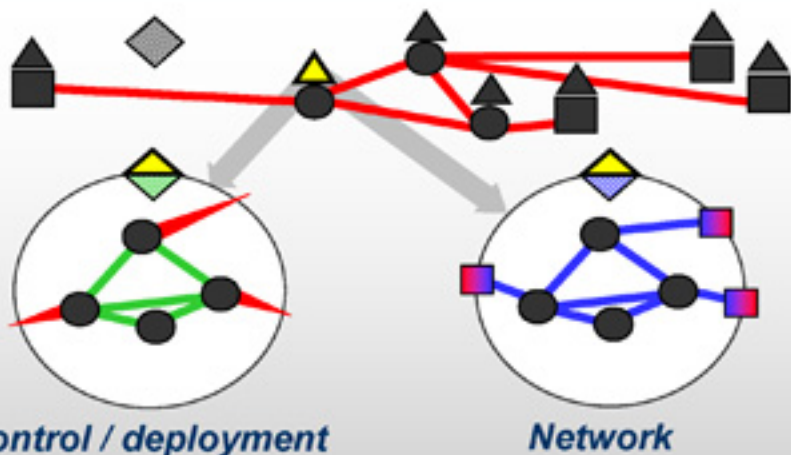

- Recursion as a router (vs. ASes)
- Network recursion examples
 - L3 = BARP (X-Bone), LISP (IRTF)
 - L2 = Rbridges/TRILL



Recursion requires new layers – where? Why?

- Wedge between (IPsec, left) or replicate (virtualization, right)

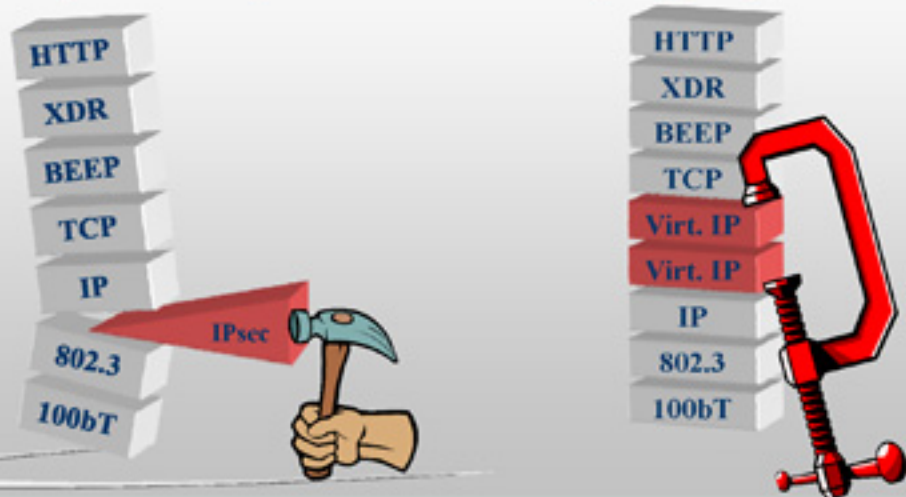



Challenges of Layering

- Which to add...
 - IPv4/IPv6, TCP/DCCP/SCTP
- When to add...
 - Security, muxing, cong. control
- Real vs. virtual
 - What's the difference?



Scope defines a layer

- Its endpoints
 - A "hop" @layer N = E2E extent of layer N-1
- The layer above
 - What services this layer provides
- The layer below
 - What services this layer requires
- E.g.: Shared state at diff. layers for diff. services
 - Application binding
 - Transport delivery
 - Net security

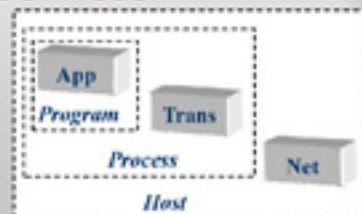

The difference is scope



Motivation for RNA

- Layers of a stack becoming more similar
 - Security, soft-state, pacing, retransmission
- Desire to support new capabilities
 - Interlayer cooperation, dynamic layer selection
- Desire to support emerging abstractions
 - Overlay layers don't map to 1-7
 - Support for recursive nodes (BARP, LISP, TRILL)

Is layering more than a coding artifact?



Observations

1. Services are relative
2. A template can avoid recapitulation
3. Composition requires coordination



Recapitulation

- Component services repeat:
 - handshake / state management
 - security
 - policy (admission control, filtering)
 - multiplexing and demultiplexing
 - retransmission
 - reordering
 - pacing / congestion control
 - switching / forwarding
- Compounded by virtualization
 - Layer on layer on layer



Composition Requires Coordination

- Many services integrate layers
 - Congestion control
 - Message boundaries
 - Security
 - State establishment
- Current interlayer interface is limited
 - Defined by each layer
 - No general security, state, etc. interface



RNA Stack

- One MP, many instances
 - Needed layers, with needed services
 - Layers limit scope, enable context sensitivity
 - Scope defined by reach, layer above, layer below





What does RNA enable?

- Integrate current architecture
 - 'stack' (IP, TCP) vs. 'glue' (ARP, DNS)
- Support needed improvements
 - Recursion (AS-level LISP, L3 BARP, L2 TRILL)
 - Revisitation
- Supports "old horses" natively
 - Dynamic 'dual-stack' (or more)



MDCM from *Choices*

Structured template w/plugin functions

- Layer address translate/resolution
 - ARP, IP forwarding lookup
 - BARP/LISP/TRILL lookup
- Layer alternates selection
 - IPv4/IPv6,
TCP/SCTP/DCCP/UDP
- Iterative forwarding
 - IP hop-by-hop,
DNS recursive queries

```

LAYER(DATA, SRC, DST)
  Process DATA, SRC, DST into MSG
  WHILE (Here <= DST)
    IF (exists(lower layer))
      Select a lower layer
      Resolve SRC/DST to next layer S',D'
      LAYER(MSG, S', D')
    ELSE
      FAIL /* can't find destination */
    ENDF
  ENDWHILE
  /* message arrives here */
  RETURN {up the current stack}
  
```



Next-hop
Resolution



Next Layer
Resolution



RNA Metaprotocol

- Template of basic protocol service:
 - Establish / refresh state
 - Encrypt / decrypt message
 - Apply filtering
 - Pace output via flow control
 - Pace input to allow reordering
 - Multiplex/demultiplex
 - includes switching/forwarding

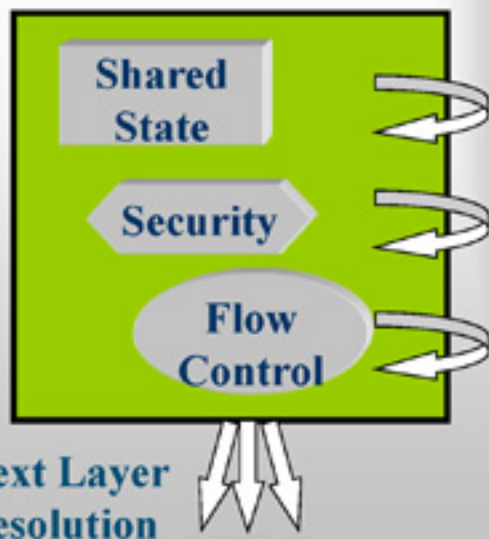

Next Layer
Resolution



Components of RNA MP

Instantiate MDCM's "Process DATA"

- Establish / refresh state
- Encrypt / decrypt message
- Apply filtering
- Pace output via flow control
- Pace input to allow reordering
- Multiplex/demultiplex as indicated
 - includes switching/forwarding



RNA MP Template

START PATTERN MIN

This simply specifies a buffer. no reordering etc.

PATTERN MIN

REQ MUST BUFFER 1

ARG BUFFER 1 VAR size 1000

LINK ADD SELF 0 BUFFER 1

...

Next use this pattern if MIN is successful

PATTERN ORDERED_DELIVERY

FOLLOWS MIN

REQ MUST REORDERING 1

LINK DEL

LINK ADD

...

If reordering successful, try more stuff...

PATTERN ENCRYPTED_ORDERED_DELIVERY

FOLLOWS ORDERED_DELIVERY

REQ MUST ENCRYPTION 1

ARG ENCRYPTION 1 VAR algo des

ARG ENCRYPTION 1 VAR keysize 512

....

Instantiation

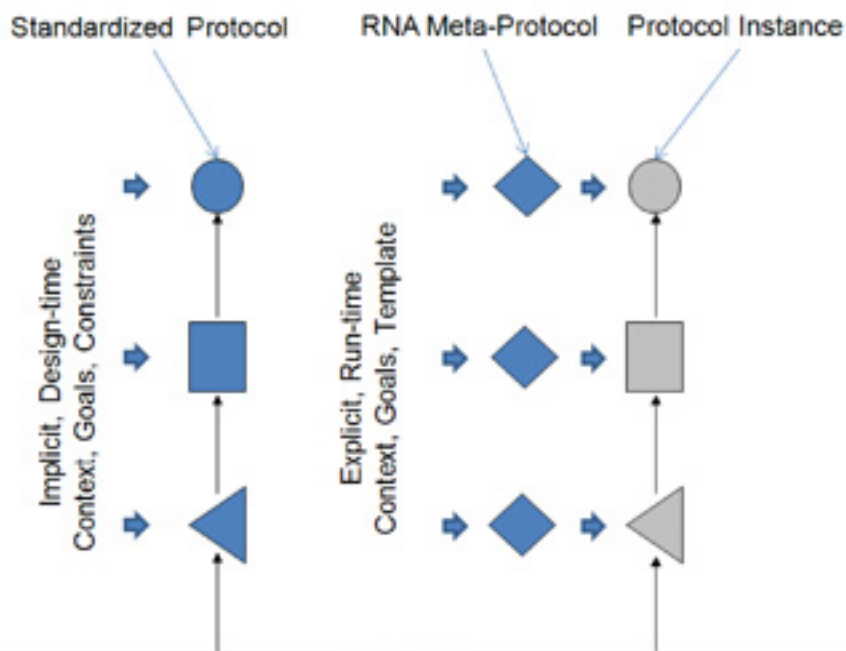



Click Implementation

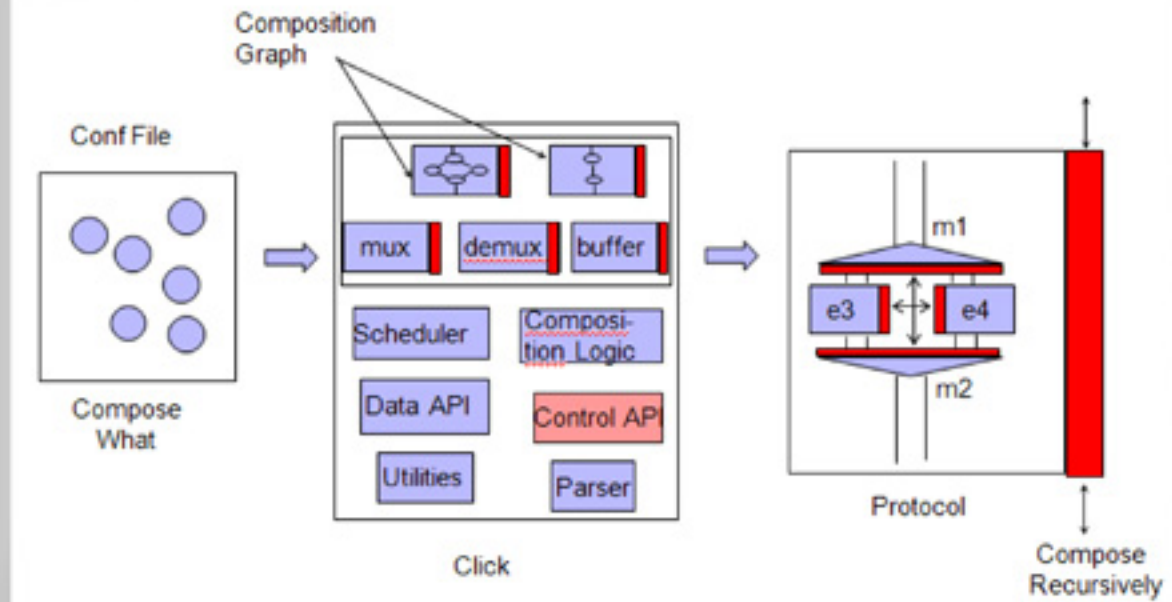

Building a Stack

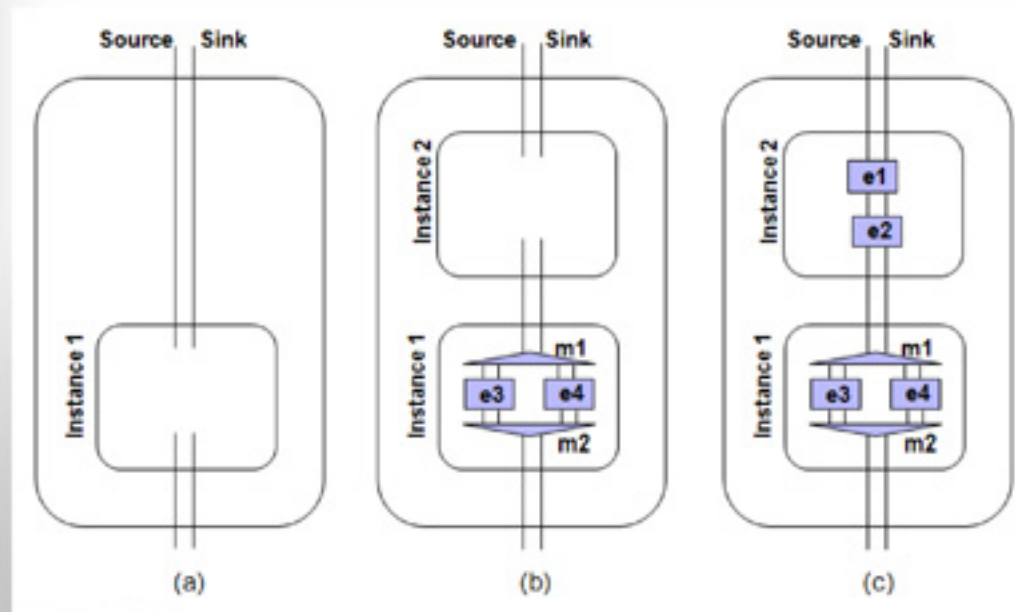

Composition Process

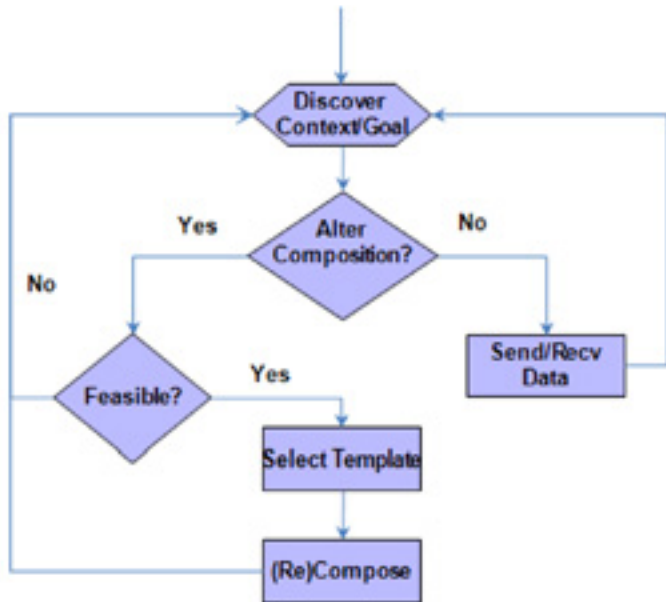



RNA – fills the gaps

- Between layers (left, from *Choices*)
 - Affects next-layer
- Between stacks (right, from Padlipsky)
 - Affects next-hop

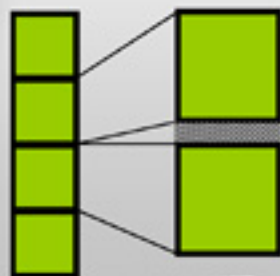



Recursion supports Layering and Forwarding

- Layering (left)
 - Heterogeneity via $O(N)$ translators
 - *Requires successive recursive discovery*
- Forwarding (right)
 - N^2 connectivity via $O(N)$ links
 - *Requires successive iterative discovery*

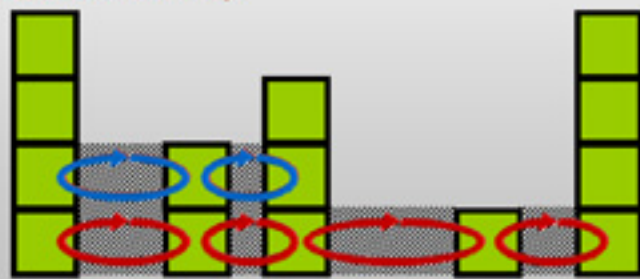
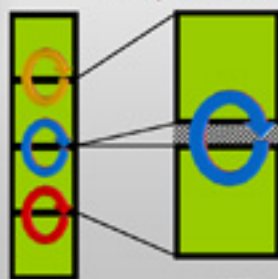



Challenges

- MP design
 - Building a sensible, generic template
- Stack management
 - Supporting instantiation and composition
- Supporting interlayer coordination
 - Designing a sensible, recursive API
 - Makes it easier to interface (to yourself, *e.g.*, LEGO)
- Supporting context sensitivity
 - Detecting environment and autotuning



Related Work Summary

- Recursion in networking
 - X-Bone/Virtual Nets, Spawning Nets, TRILL, Network IPC, LISP
 - *RNA natively includes resolution and discovery*
- Protocol environments
 - Modular systems: Click, x-Kernel, Netgraph, Flexible Stacks
 - Template models: RBA, MDCM
 - *RNA adds a constrained template with structured services*
- Context-sensitive components
 - PEPs, Shims, intermediate overlay layers, etc.
 - *RNA incorporates this into the stack directly*
- Configurable über-protocols
 - XTP, TP++, SCTP
 - *RNA makes every layer configurable, but keeps multiple layers.*



RNA and Network IPC

- Similarities
 - Recursive protocol stack
 - Unified communication mechanism
 - Focus on process-to-process interaction
- Differences
 - RNA uses MDCM to define IPC as combining a Shannon-style channel with namespace coordination
 - RNA provides a detailed (and demonstrated) mechanism that achieves unification and recursion
 - RNA supports both recursion and forwarding in a single mechanism



Protocol & Transit Domains

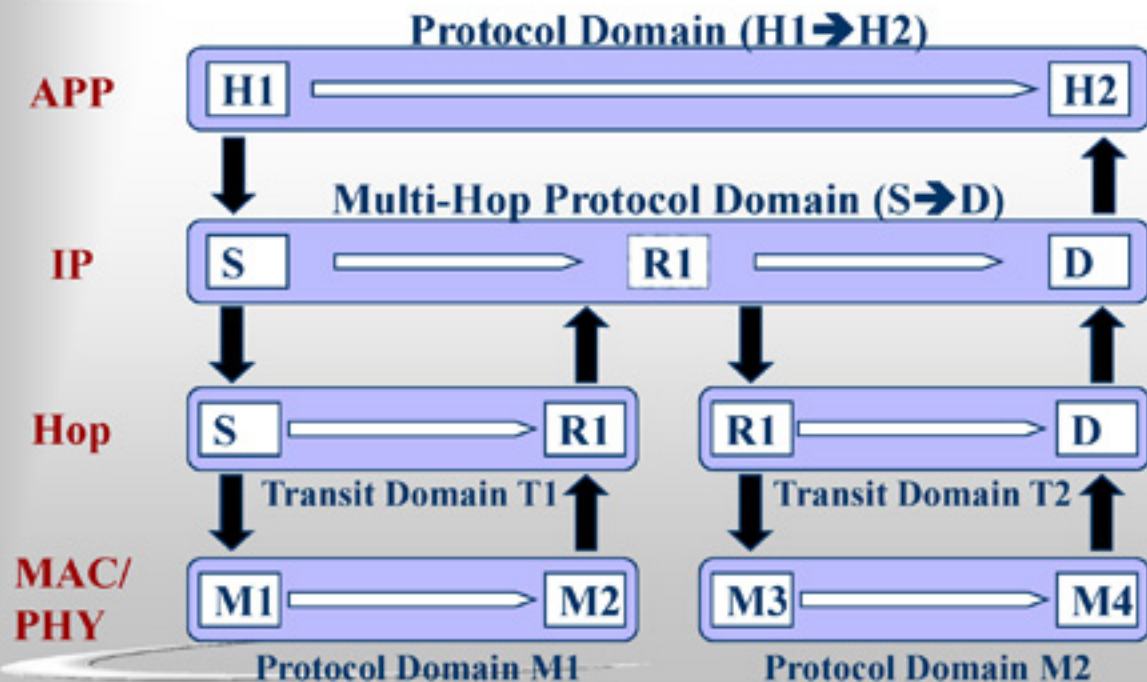



Conclusions

- Virtualization requires recursion
- Recursion supports layering
- Recursion supports forwarding

One recurrence to bind them all...

- ***Recursion is a native network property***
 - Integrates and virtualization, forwarding and layering
in a single mechanism